

**C100**  
MANUAL



## C100 OPERATING, INSTALLATION, AND SERVICE MANUAL

Congratulations on your choice of the *Culligan C100 Water Treatment System*. The *C100 Water Treatment System* dispenses cold, and hot. Every *C100 Water Treatment System* includes:



*Bio-Cote Anti-Microbial Protection*



*Filter configuration can be optimized for all water conditions*

The *Culligan C100 Water Treatment System* provides exceptional quality and great tasting water with every use.

## INTRODUCTION

Carefully read and follow all instructions to ensure proper and efficient operation of your *C100 Water Treatment System*. Contact *Culligan* or an *Authorized Culligan Dealer* if you have any questions.

*Culligan* and *Authorized Culligan Dealers* employ trained service personnel who are experienced in the installation, function and repair of *Culligan* equipment. This publication is written for use by these qualified individuals. *Culligan* encourages users to learn about products, however, we believe that product knowledge and service is best obtained by consulting *Culligan* or an *Authorized Culligan Dealer*.

*Culligan* water treatment systems should be combined with selected water treatment components to create a system specifically tailored for each application by trained and qualified personnel.

Products manufactured and marketed by *Culligan* and its affiliates are protected by patents issued or pending in the United States and other countries.

*Culligan* reserves the right to change the specifications referred to in this literature at any time, without prior notice. Changes or modifications not expressly approved by *Culligan* could void the warranty and user's authority to operate the equipment.

*Culligan* technical manuals cover voltages of both 120v and 220v for all our markets. Please ensure that you carefully read the information in this manual and for any parts specific to any market, refer to your technical agreement or specific part listing.

## TABLE OF CONTENTS

### USER GUIDE

- Safety Alert Symbols ..... 4
- Safety Precautions..... 4
- Features and Benefits..... 6
- Certifications ..... 7
- Model Designations and General Specifications ..... 8
- Electrical and Shipping Specifications ..... 9
- Operating Instructions ..... 10

### SERVICE GUIDE

- Service Requirements..... 11
- Installation Rail..... 12
- Hot Tank Operation..... 13
- Heater Circuit ..... 14
- Resetting the Hot Tank Overheat (High Limit Safety) ..... 15
- Hot Tank Descaling..... 17
- Recommended Stock Holding (Consumables) ..... 19
- Mini Exploded Diagram and Parts List..... 20
- Free Standing Exploded Diagram and Parts List..... 25
- Flow Diagram ..... 31
- Electrical Schematic Diagrams..... 33

### INSTALLATION GUIDE

- Pre-delivery Inspection ..... 35
- Mini Draining Procedure ..... 38
- Free Standing Draining Procedure ..... 40
- Installation Instructions..... 42

### TROUBLESHOOTING GUIDE

- Power Troubleshooting ..... 45
- Dispense Troubleshooting..... 48
- Cold Water Troubleshooting ..... 59
- Hot Water Troubleshooting ..... 60



## SAFETY ALERT SYMBOLS

Read and follow all safety information carefully. The signal words used in this manual are selected as shown below and based on an assessment of the degree of potential injury or damage (severe or minor) and the occurrence of injury (definitely occurs or has the potential to occur) when the warning is ignored:

 **DANGER!**

*Indicates a situation which, when not avoided, results in death or severe injury.*

 **WARNING!**

*Indicates a situation which, when not avoided, has the potential to result in death or severe injury; and/or severe property damage.*

 **CAUTION!**

*Indicates a situation which, when not avoided, results or has the potential to result in minor injury; and/or minor property damage.*

## SAFETY PRECAUTIONS

### Basic safety precautions should be followed, including the following:

Ensure all local laws and codes including health and safety guidelines are met when installing **Culligan** Equipment. Only qualified service technicians should attempt installation and service of **Culligan** Equipment. Always read the entire operating instructions before using the appliance and save these instructions for future use.

 **DANGER! ELECTRICAL SHOCK HAZARD.** Always use a dedicated and properly earthed outlet. Unit should be protected by residual current device (RCD) having a rated residual operating current not exceeding 30mA. Use only Culligan supplied power cord. Never use extension cords or power strips to connect unit. Do not use if the power supply cord is damaged. Always unplug from power supply prior to servicing.

 **WARNING! AUTHORIZED USE ONLY.** This appliance is to be used for its intended purpose as described in this manual, and untrained individuals who use this manual assume the risk of any resulting property damage or personal injury. This appliance can be used by children aged from 8 years and above and persons with reduced physical, sensory or mental capabilities or lack of experience and knowledge if they have been given supervision or instruction concerning use of the appliance in a safe way and understand the hazards involved.

 **WARNING! SUPERVISE CHILDREN.** Keep appliance and cord out of reach of children under the age of 8 years. Children under the age of 8 years must not use or play with the appliance.

 **WARNING! DO NOT OPERATE IF DAMAGED.** Unplug for safety. Contact Culligan or authorised dealer for repair, service, and installation to avoid hazards.

 **WARNING! HOT WATER.** Unit produces Hot Water in excess of 87°C (188°F). Water above 52°C (125°F) can cause severe burns or scalding. Keep unauthorized people and children away from the unit to avoid accidental dispensing of hot water.

 **WARNING! CONNECT TO POTABLE WATER SUPPLY.** *This system is to be used for water only and is not intended for use where water is microbiologically unsafe or with water of unknown quality without adequate disinfection. System is designed for the supplemental bactericidal treatment of public drinking water, or other drinking water, which has been tested and deemed acceptable for human consumption by the water provider. The system is designed to reduce normally occurring non-pathogenic or nuisance microorganisms only. System is not intended for treatment of contaminated water.*

 **WARNING! TIP HAZARD.** *Dispenser could tip or fall causing serious injury. Always install unit on a firm, flat, and level surface and secure the **C100 Water Treatment System** to the base cabinet with the screw provided to lock the components together. Secure unit to cabinet, wall, or floor if needed. Never place heavy items on top of unit and never climb, stand, or hang on unit or storage cabinet to prevent injury and damage.*

 **WARNING! UNIT IS HEAVY. TWO PERSON LIFT REQUIRED.** *Transport unit empty and always use material handling equipment or two people with proper lifting technique to reduce injury risk.*

 **WARNING! STORE AND TRANSPORT UNIT EMPTY. ALWAYS SANITISE BEFORE USE.** *The unit must be completely drained and sealed before storing to avoid stagnation and reduce microbiological contamination (potential bacterial growth). Sanitise before use to eliminate any potential microbiological contaminants.*

 **CAUTION! INDOOR USE ONLY.** *Intended for household use only. Never expose to direct sunlight, heat sources, or ambient air temperature above 37°C (100°F) or below 2°C (35°F). Install indoors and keep unit away from excessive humidity. Never expose to freezing temperatures. Ensure there is adequate clearance around the unit (50mm minimum) to allow refrigeration system condenser to dissipate heat. Warmer environments require more clearance around the unit. Installs where the ambient temperature exceeds 27°C (80°F), require a minimum of 100mm clearance for proper heat dissipation and efficient operation.*

 **CAUTION! USE A WATER PRESSURE REGULATOR.** *Culligan will not be responsible for injury or damage caused by excessive water pressure. Input or feed pressure must be 2.7Bar to 4Bar. Be aware of any potential pressure surges caused by building/municipal pumping stations. Water block devices and external leak detectors are strongly recommended. Locate the unit as close to the water supply and the electrical connections as possible to minimize risk.*

 **CAUTION! USE PROPER SUPPLY LINES AND FEED WITH POTABLE AMBIENT WATER ONLY.** *Feed water over 37°C (100°F) may damage the treatment components. Always use supply lines with adequate pressure rating and UV resistance. Close water supply valve and contact service representative if a leak is noticed.*

**Contact Culligan for assistance or help finding an Authorized Service Representative.**

## C100 FEATURES AND BENEFITS

### Ambient, Cold and Hot Water

Ambient, Cold and Hot Water Selections to meet a wide range of customer demands.

### High Volume Storage and Water Capacity

**C100 Water Treatment Systems** have 2 Litre (0.44 Gallon) Cold Tank and 1.5 Litre (0.33 Gallon) Hot Tank.

### BioCote® Anti-Microbial Protection

Certain plastic, silicon, and painted surfaces surrounding the dispensing areas and drip tray are infused with an exclusive additive called BioCote®. BioCote® provides an effective barrier against microbes like bacteria and mould, which may cause odour or staining.



### Recessed Faucet

BioCote® Faucet (Spigot) is recessed into unit to protect from cross contamination.

### Large Dispense Area

22 cm (8.5 inch) dispense height to accommodate most cup and bottle sizes.

### Child Safeguard

The **C100 Water Treatment System** requires user to select and hold both Red Buttons to prevent accidental dispensing of hot water.

### Energy Saving Sleep Mode

Energy Saving Sleep Mode can be programmed to turn off Heater after 3 hours of inactivity.

### Stainless Steel Tanks

Peace of mind drinking from high quality, sealed stainless steel reservoirs.

### Advanced Filtration

The **C100 Water Treatment System** Free Standing equipped with easy access filter mounting tray that allows dealers to optimize filter configuration for all water conditions.

### High Capacity Removable Drip Tray

High Capacity Removable Drip Tray with BioCote® protection. Drip tray is two-piece for easy cleaning and comes configured with optional drain port.



## C100 CERTIFICATIONS

*Culligan Water Treatment Systems* have been tested, and certified to rigorous CE, NSF and UL Standards. We believe that performance testing and certifications validate *Culligan* as a world-leader in water treatment systems.

### C100 Water Treatment System Certifications Include



#### UL399 – Certified Drinking Water Cooler

Intertek Labs (ETL) Certified the *C100 Water Treatment System* to ANSI/UL 399 Standard for Drinking Water Coolers.



BPA Free - *Culligan* tests for BPA and declares that all of its products are Bisphenol-A FREE and contain no harmful BPA plastics.



This system is certified by IAPMO R&T according to NSF/ANSI-61 – Certified Drinking Water System Components, NSF / ANSI 372 – Drinking Water System Components for low Lead Content, and CSA B483.1 - Drinking Water Treatment Systems.



*Culligan* is certified to ISO 9001:2015 – Quality Management Systems (certified by Intertek). ISO 9001 is the internationally accepted standard for well managed organizations that have adopted the key quality management principles to its operations to bring consistent quality products and a culture of continuous improvement.



## MODEL/PART DESIGNATIONS

BRAND NAME	DESCRIPTION	MODEL - PART NUMBER
<b>C100</b> Mini	<b><i>Culligan C100 Mini</i></b>	100-M
	F-100-M-HC-TT-CS-WLT – Hot and Cold F-100-M-CA-TT-CS-WLT – Cold and Ambient	
<b>C100</b> Free Standing	<b><i>Culligan C100 Free Standing</i></b>	100-FS
	F-100-FS-HC-TT-CS-WLT – Hot and Cold F-100-FS-CA-TT-CS-WLT – Cold and Ambient	

## SPECIFICATIONS

ITEM	<b><i>C100</i></b> Mini	<b><i>C100</i></b> Free Standing
Power Supply	220V/50Hz or 120V/60Hz	
Water Connection	¼" Quick Connect	
Cold Water Temperature	Cold Water Temperature – Factory Set Point 5°C (41°F)	
Cold Tank Size	2 Litre (0.44 Gallons)	
Hot Water Temperature	85°C (185° F)	
Hot Water Manual Reset Overload	105°C (221° F)	
Hot Tank Size	1.5 Litre (0.33 Gallons)	
Drip tray size	1.3 Litre (0.28 Gallons)	
Recommended Service Pressure	2.5-3.5 Bar – Always Use Pressure Regulator	
Maximum Service Pressure	4 bar – Use Pressure Regulator	
Rated Service Flow	1.89 Litres per minutes (0.5 gallons per minute)	
Environmental Temperature	2° - 37°C (35° - 100°F)	
Heater	500 W	
Refrigerant Gas	R600a: 20 g   R134a: 40 g	R600a: 21 g   R134a: 45 g



## ELECTRICAL SPECIFICATIONS

<b>ELECTRICAL SUPPLY</b>	<b>220V/50Hz or 120V/60Hz</b>	<b>120V/60Hz</b>
<b>COMPONENT</b>	<b>POWER (approximate)</b>	<b>Amperage (approximate)</b>
Heater	500 Watts	4.2
Compressor	90 Watts	1.4
Control Unit	10 Watts	0.15
<b>C100 TOTAL</b>	<b>600 Watts</b>	<b>5.75</b>

## PRODUCT DIMENSIONS

<b>ITEM</b>	<b><i>C100 Mini</i></b>	<b><i>C100 Free Standing</i></b>
Width/Depth/Height	345 mm x 367 mm x 450 mm (13.58" x 14.45" x 17.74")	345 mm x 367 mm x 1022 mm (13.58" x 14.45" x 40.24")
Weight (dry)	18 kg (40 pounds)	23 kg (50 pounds)

## OPERATING INSTRUCTIONS

### **DISPENSING YOUR CHOICE OF WATER IS VERY SIMPLE, AS FOLLOWS:**

1. Place your cup centrally in the dispensing area
2. Select the type of water you wish to be dispensed and press the corresponding button.
3. Keep the button depressed until your cup has reached the desired level, and then release the button.

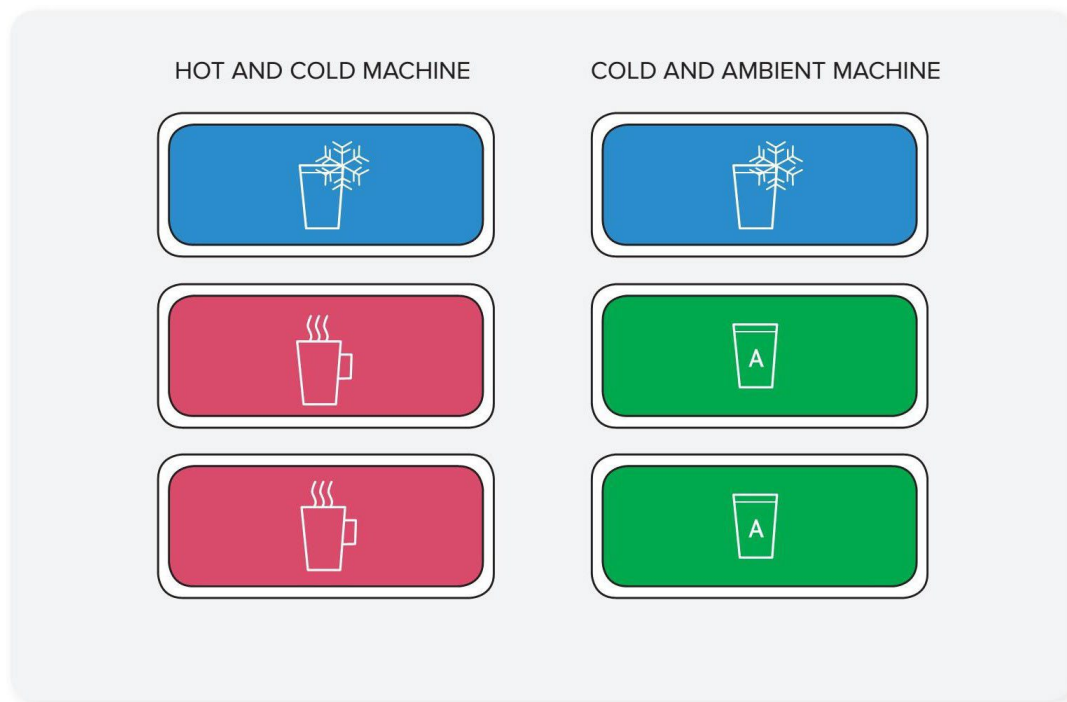

#### **COLD WATER**

Push the cold water button (blue). Cold water dispenses.



#### **HOT WATER** ⚠️

Push the 2 hot (red) buttons together. Hot water dispenses.



#### **AMBIENT (NON-CHILLED) WATER**

Push the 2 ambient green buttons together. Ambient water dispenses.



#### **HOT WATER CAUTION**

- Always place cup / mug in the centre of the drip tray.
- Always use a ceramic cup or a cup suitable for use with hot water.
- Do not hold cup or place hands in dispensing area whilst dispensing water.
- Do not dispense water in a stop start style of vending (Hold the button continuously until cup is full).
- Never try to fill more than one vessel at a time.

## SERVICE REQUIREMENTS

 **WARNING!** *Read and understand the contents of this manual before attempting to service C100 Water Treatment System. Failure to follow the instructions in this manual could result in death, serious personal injury, or severe property damage. Only trained and qualified technicians should attempt to install, maintain, or service Culligan Equipment.*

1. Visually inspect all electrical and water connections for signs of wear or damage.

 **DANGER!** ***HIGH VOLTAGE ELECTRICAL HAZARD.** Unplug before inspection and service.*

2. Ensure there is adequate (minimum of 50 cm) clearance around the unit and clean the Condenser Grill and Compressor fan to provide efficient cooling system operation.
3. Sanitize the Cold Tank per instructions in the pre-installation procedures.
4. Clean and sanitize external surfaces of the unit. Use only chemicals that are compatible with ABS plastic and will not damage or degrade the product surfaces.
5. Remove and clean the Faucet. Replace as needed.

 **WARNING!** ***SANITIZER MAY CONTAIN HAZARDOUS CHEMICALS.** Use of proper personal protective equipment such as rubber gloves and eye protection is required.*

## INSTALLATION RAIL

**⚠ WARNING! ALWAYS USE INSTALL RAIL.** It is required to use an installation rail for the installation of any **Culligan Water Treatment System**. Failure to use an installation rail can result in damage due to excessive pressures over a prolonged period of time and no additional leak protection. Please check local water bylaws, in some countries an installation rail is a legal requirement. Parts required may vary due to local regulations. Always refer to local installation guidelines and regulations

**⚠ CAUTION! ALWAYS INSTALL VERTICALLY.** Do not install installation rail horizontally as this will affect the performance of the water block.

← Water inlet – 15mm compression fitting

← Isolation valve – Quarter turn to isolate.

Open
 Closed

← Double check valve – only allows water to flow one way, no adjustment needed.

← Pressure Reducing Valve – Reduces the pressure from any high pressure down to 3bar +/- 0.5bar. The pressure reducing valve is an essential part of the installation rail and ensures that the Culligan Water Treatment System is not exposed to high pressures over a prolonged period of time.

← Water block – The water block will shut the flow of water in the event that a leak has taken place. This works by measuring the velocity of water and shutting off water flow. Adjustment and reset can be made by pressing or turning the red dial located on the front face of the water block.

← **Adjustment Settings: 1.3 to 13.2 gallons(6-60Litres)**  
 \*Note Every notch increases the set volume by 1.5 +/- gallons (5 +/- litres)

**Pressure Requirements: 10 - 125 PSI (0.7 - 8.6 bar)**

**Ambient Temperature: 35 - 140°F (2 - 60°C)**

**Fluid Temperature: 35 - 158°F (2 - 70°C)**

**Flow Rate: 0.53 - 7.9 GPM (2 - 30 Lpm)**

**Resistance to Bursting: 725.19 PSI at 77°F (>50 bar at 25°C)**

← 3/4" to 1/4" John Guest adaptor – Allows the connection of 1/4" John Guest PE pipework from the install rail to the bulkhead of the machine.

## HOT TANK PRINCIPLES OF OPERATION

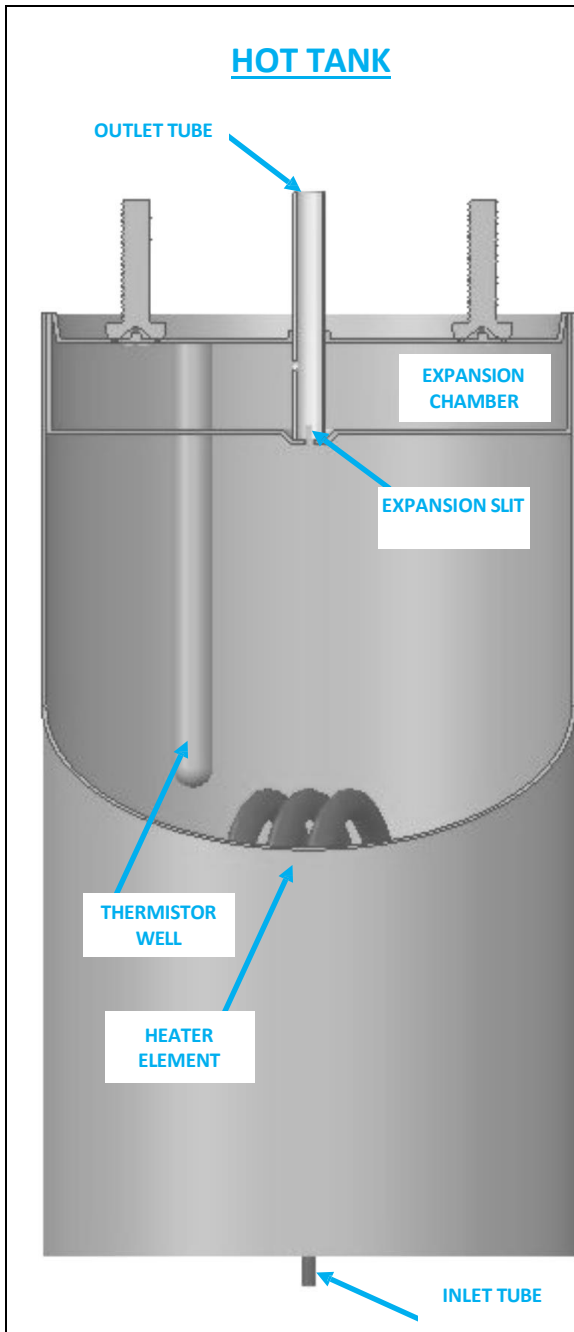

All **Culligan** Hot Tanks have a built-in Vent or Expansion Chamber in the top of the tank except for C1000GF units.

The Vent Chamber allows for expansion of the water when it is heated.

The chambers are separated by a welded-in tank baffle.

Water always flows into the bottom of the tank and out the top to the faucet.

The hot tank outlet tube has a restrictor in its base. This ensures the reservoir is always full by allowing more water in than out.

There is a small hole in the side of the tank outlet tube that allows air and water to pass into the vent chamber as it is heated.

Water in the vent chamber is suctioned back through the outlet tube vent hole when water is dispensed.

Expansion of water as it is heated in the reservoir will push the water out the faucet when the outlet tube vent hole becomes plugged with debris or scale.

The small Outlet Vent Hole is susceptible to scale build up and is a key indicator that descaling is required.

It is critical to descale the Hot Tank through the vent line and outlet line on a regular basis to prevent this problem.

Descaling through the inlet and/or outlet lines only will not clean the vent chamber and outlet vent hole properly.

HEATER CIRCUIT

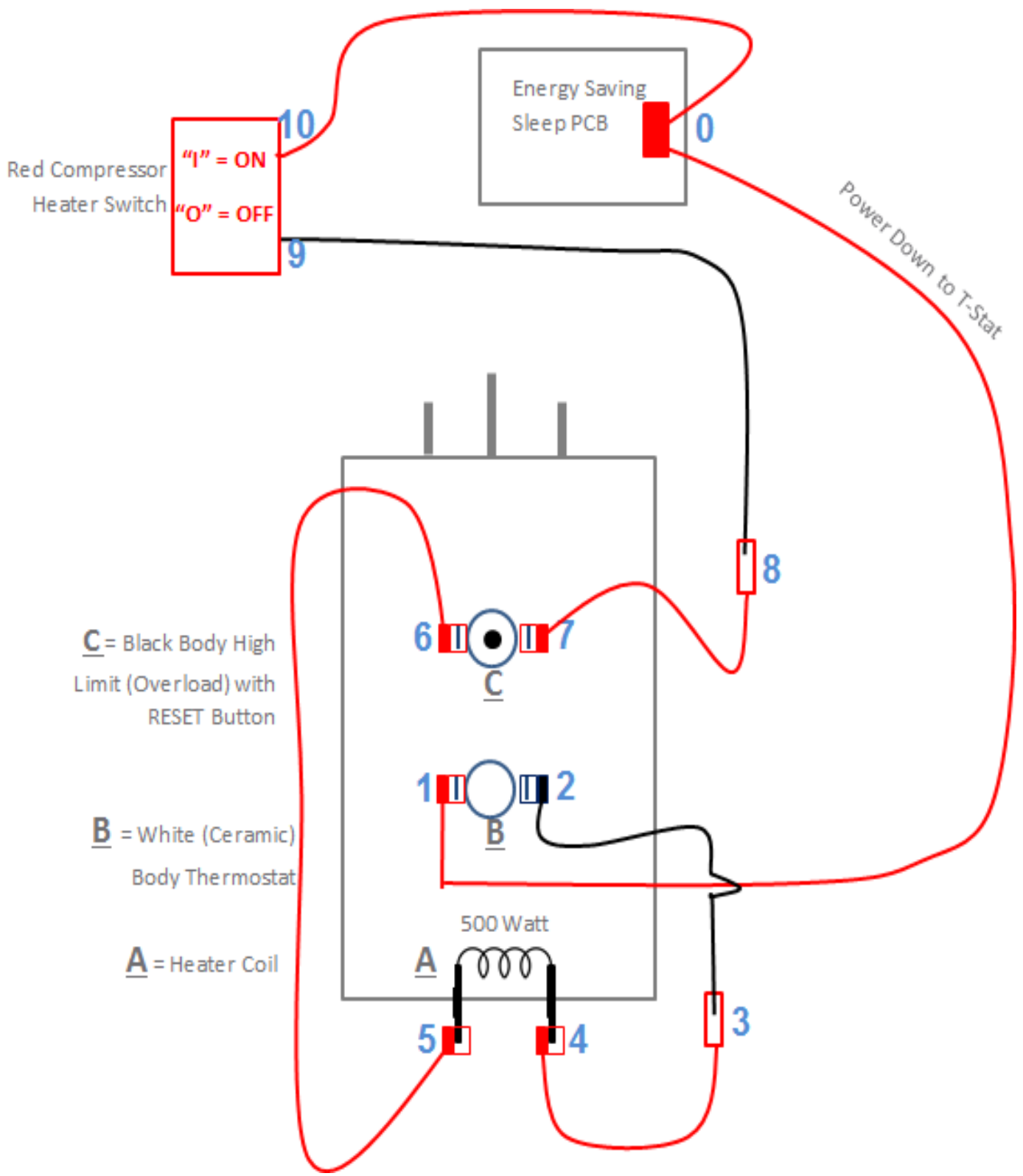





C = Black Body High Limit (Overload) with RESET Button

B = White (Ceramic) Body Thermostat

A = Heater Coil

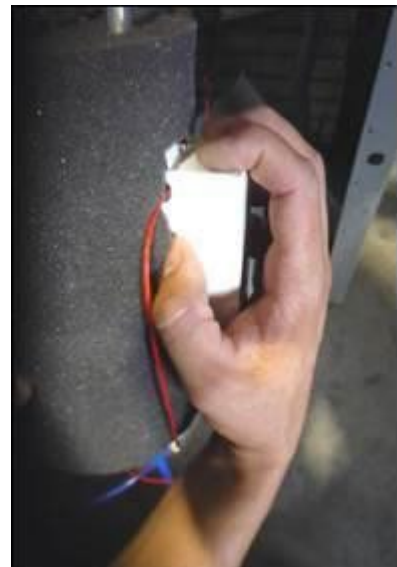
## RESETTING THE HOT TANK OVERHEAT OR HIGH LIMIT SAFETY

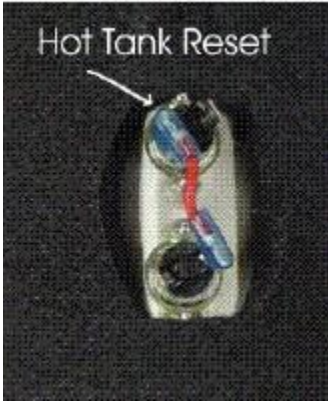
1.	<p>Red Heater and Compressor Switch must be in the OFF position</p> <p><i>O=OFF</i></p>
	
2.	<p>Unplug the Power Cord from rear of <b>C100 Water Treatment System</b>.</p>
3.	<p>Free Standing Model: Remove the <u>Lower Front Panel</u> by removing the Phillips Head Screws underneath the Lower Front Panel.</p> <p>Counter Top Model: Remove the <u>Side Panel</u> by removing Phillips Head Screws from Side Panel.</p>
4.	<p>Locate the protective metal box on the rear of the Hot Tank.</p> <p>As you look through the condenser coils on the rear of the unit, you will see the Hot Tank located on the right hand side.</p>
	
5.	<p>Reach up behind the Hot Tank and take hold of the Protective Metal Box covering the Thermostat and Overheat on the Hot Tank.</p> <p>There are nuts that secure the metal box to the Hot Tank. However, the nuts are loose enough to allow you to remove the metal box.</p> <p>If the nuts on the metal box are too tight, loosen the nuts securing the Hot Tank to the upper base of the unit and lower the hot tank so you can remove the metal box.</p> <p><i>For demonstrative purposes, photos below have lowered the Hot Tank from the unit.</i></p>
	

<p>6.</p>	<p>Press the reset button</p>  <p>The image shows a small, rectangular metal box with a red button in the center. The text "Hot Tank Reset" is printed above the button, with a white arrow pointing to it.</p>	 <p>A close-up photograph showing a person's hand using a pair of red-handled pliers to press the red reset button on the metal box.</p>
<p>7.</p>	<p>Reattach the metal box by depressing the top flap of the Metal Box so it snaps back into its original position on the Hot Tank.</p>	 <p>A close-up photograph showing a person's hand snapping the metal box back into its original position on the hot tank. The box is held against a dark, textured surface.</p>
<p>8.</p>	<p>Replace Panel on unit using Phillips head screws.</p>	
<p>9.</p>	<p>Plug in the Power Cord.</p>	
<p>10</p>	<p>Make sure the Hot and Cold Tanks are filled with water BEFORE turning on the Red Heater and Compressor Switch.</p> <p>Verify the cooler is fully operational before installing it at the customers' site.</p>	





## HOT TANK DESCALING INSTRUCTIONS

The Hot Tank requires removal of mineral deposits (descaling) on a regular basis. Typically descaling should take place every 6 to 12 months to preserve the long-term health of your unit.

Use non-toxic cleaner such as ScaleKleen, DEZCAL or 20% Citric Acid Solution to remove mineral deposits as directed by the manufacturer depending upon filtration and local water conditions.

Descaling is an important process that removes calcium deposits, or scale, that can build up inside a tank over time. Calcium and scale is non-toxic but if left unattended will hinder your unit's performance.

 **WARNING!** *PERSONAL PROTECTIVE EQUIPMENT REQUIRED.* Always ensure proper ventilation and use rubber or nitrile gloves and eye protection when using chemicals. Refer to Material Safety Data Sheet for specific requirements of each product.

 **CAUTION!** *STAINLESS STEEL TANK DESCALING.*  
*The Hot Tank is made from stainless steel. Ensure descaling solution is compatible with stainless and always flush the unit completely. Dispose in an environmentally safe manner.*

### Materials Needed:

- Personal Protective Equipment. Rubber or Nitrile Safety Gloves and Protective Eyewear
  - Phillips Screwdriver
  - Temperature Gauge
  - Water Pitcher or Container to collect water from the faucet
  - 20 Litre container or drain basin
  - Citric Acid Based Cleaner
  - ¼" Plastic Tubing, at least 1m in length, and assorted ¼" quick connect fittings
  - Empty Cartridge
1. Ensure installed filters are removed and bypass as necessary.
  2. Put descaler solution as per directions into the empty cartridge.
  3. Connect descaling cartridge to the inlet water supply and connect to inlet bulkhead fitting on the back of the **C100 Water Treatment System**. Turn on Water Supply.
  4. Select Hot Water and depress the Main Dispensing Button on the Front Control Panel until descaling solution (cloudy water) comes out of the faucet. Pinch the hot water overflow tube to ensure sub tank is full with descale solution. Container and drain basin will be required to catch water from the faucet.
  5. Turn off water supply and remove the empty cartridge from inlet water supply. Reconnect water supply to inlet fitting.

6. Allow descaling solution to remain in the Hot Tank and sub tank for 15 minutes (length of time may vary depending on water conditions).
7. Place a pitcher, catch basin or other container under the faucet of the **C100 Water Treatment System**.
8. Flush the Hot Tank until water runs clear, ensure you pinch the hot water over flow tube to drain and clear the sub tank.
9. Once clear Water dispenses from the faucet the Hot Tank has been descaled. Always ensure the **C100 Water Treatment System** is performing to the customer's satisfaction.

 **WARNING! HOT WATER.** *The C100 Water Treatment System produces Hot Water up to 87°C (189°F). Water above 52°C (125°F) can cause severe burns or scalding. Hot water should be dispensed carefully into insulated container to avoid injury.*

 **WARNING! REINSTALL ALL PANELS AND COVERS.** *Always reinstall all Panels, Protective covers, and fasteners after servicing equipment. Failure to do so could result in severe personal injury and will void the certifications and warranty of the equipment.*

## RECOMMENDED STOCK HOLDING (CONSUMABLES)

*Culligan* technical manuals cover voltages of both 120v and 220v for all our markets. Please ensure that you carefully read the information in this manual and for any parts specific to any market, refer to your technical agreement or specific part listing.

Recommended Spare Part	Amount per 10 machines
Solenoid Valve (recommend replacing Solenoid Cushion at same time)	2
Solenoid Cushion	2
Faucet	2
Display PCB	4
Drip Tray No Logo	4
Drip Tray Grill	4
Overheat with Manual reset-97°C	2
Hot Tank 1.5 Litre 220-240V / 500W Factory Set Point 85°C (185°F)	2
Hot Tank 1.5 Litre 120v/500W Factory Set Point 85°C (185°F)	

Replacement parts can be obtained from *Culligan* or an *Authorized Culligan Dealer*. See **Parts Layouts, Drawings, and Lists** for additional repair parts.

### Sanitizing

Sanitization must be performed at least once a year to eliminate any potential microbiological contaminants. See Sanitizing Instructions in the Pre-Installation section of this manual.

### Hot Tank Service

Hot Tanks (with controls) must be replaced at least every 3-5 years depending on usage. Descaling Hot Tank may be required on a regular basis depending upon filtration and local water conditions. See Hot Tank Descaling Instructions Section of this manual.

### NOTE:









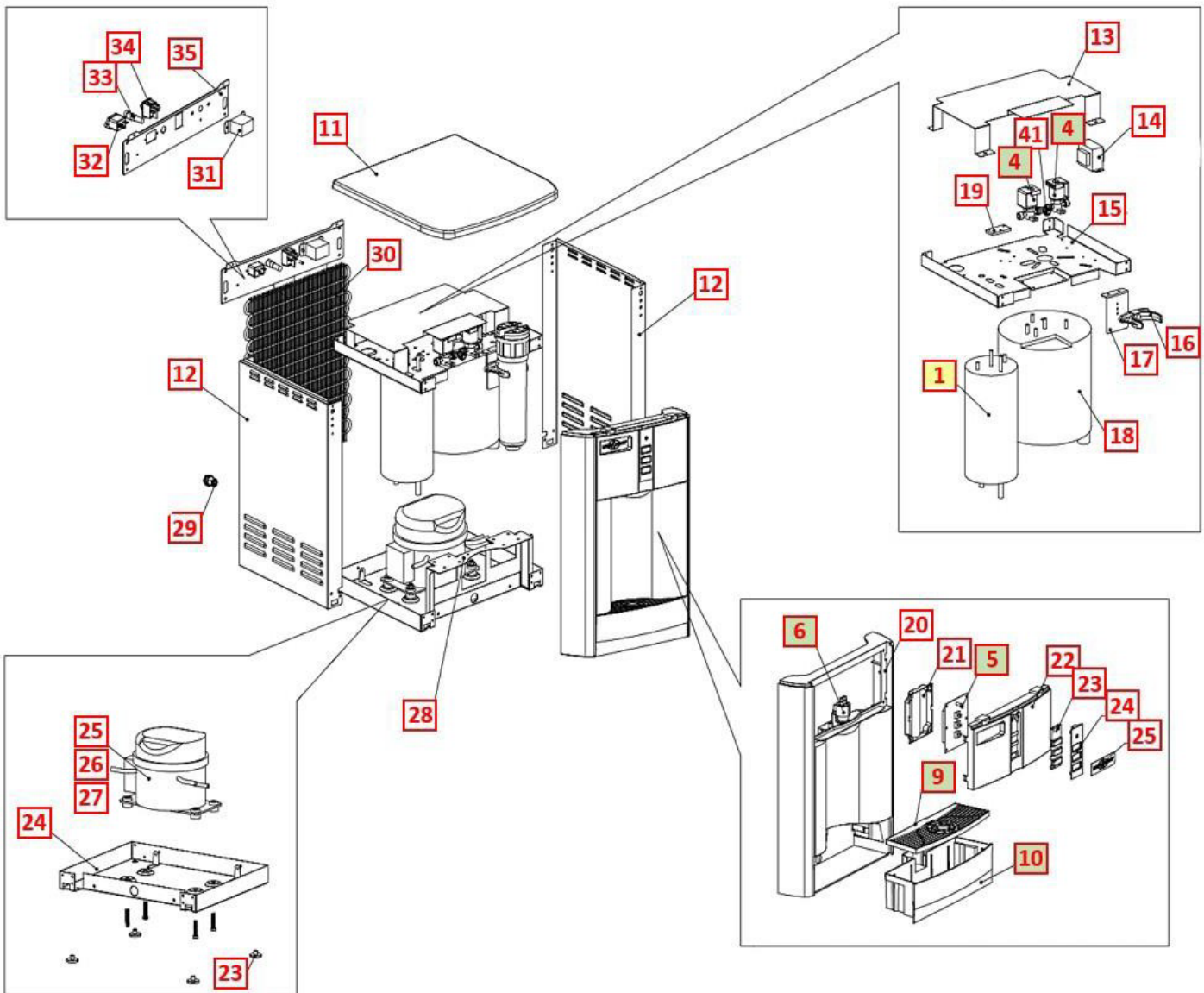
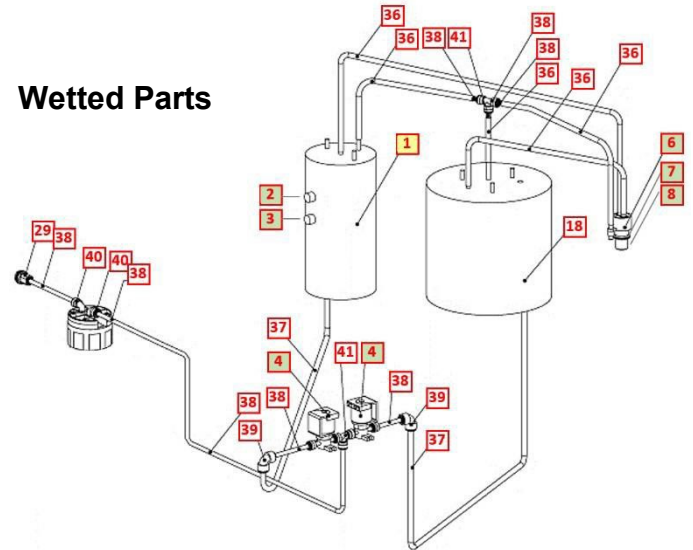



At the **end of this product's life**, ensure that it is disposed of in an environmentally friendly manner which is fully compliant **with all Local Requirements and Guidelines**.



## C100 MINI DRAWINGS AND PARTS LIST

Yellow = Consumables
Green = Recommended spare parts















### Wetted Parts





No	Description	
1	Hot Tank 1.5 Litre 220-240V / 500W Factory Set Point 85°C (185°F) Hot Tank 1.5 Litre 120v/500W Factory Set Point 85°C (185°F)	
Not Shown	GAC Filter - 10" Carbon Activated Inline Filter – <b>Optional</b>	
Not Shown	Carbon Block - 10" CBC 1 Micron Lead and Cyst Reduction Inline Filter – <b>Optional</b>	
2	Overload with Manual Reset 97° C <i>Recommend stocking 2 each for every 10 units purchased</i>	
3	Hot Tank Thermostat 85°C <i>Recommend stocking 2 each for every 10 units purchased</i>	
4.1	Solenoid Cushion <i>Recommend stocking 5 each for every 10 units purchased</i>	
5	Main PCB <i>Recommend stocking 2 each for every 10 units purchased</i>	
6	Faucet Assembly <i>Recommend stocking 2 each for every 10 units purchased</i>	
7	Natural Faucet O-Ring – Silicon White <i>Recommend stocking 2 each for every 10 units purchased</i>	
8	Faucet Nipple – Blue with Screen <i>Recommend stocking 2 each for every 10 units purchased</i>	
9	Drip Tray Grill Charcoal <i>Recommend stocking 5 each for every 10 units purchased</i>	
	Drip Tray Grill – Blue <i>Recommend stocking 5 each for every 10 units purchased</i>	

10	Drip Tray Body – Charcoal No Logo <i>Recommend stocking 5 each for every 10 units purchased</i>		
	Drip Tray Body – Blue No Logo <i>Recommend stocking 5 each for every 10 units purchased</i>		
11	Top Cover Flat - Charcoal Textured		
	Top Cover Flat – Blue		
12	Side Panel – <b>Counter Top only</b>		
13	High Voltage Cover <b>Counter Top Only</b>		
14	Power Transformer 230V / 50Hz Power Transformer 120V / 60Hz		
15	Upper Shelf <b>Counter Top Only</b>		
16	2.8" Filter Clip for In-Line Filter		
	3" Filter Clip for In-Line Filter		
17	Filter Bracket <b>Counter Top Only</b>		
18	2 Litre Cold Tank <b>Countertop Only</b>		
20	Front Upper Drip Tray Insert Panel - when purchasing, also request Hot Water Caution Label LP-7169 to adhere to front of this Panel.		

20.1	Hot Water Caution Label – <i>Adhere to Front Upper Drip Tray Insert Panel.</i>		
21	Front PCB Cover		
22	Front Upper Insert Panel - Charcoal		
	Front upper Insert Panel – Blue		
23	Silicon Button Key mat		
24	Button PCB Insert Panel - Silver		
25	<b>C100</b> Label – Front Upper Insert Panel		
23	Unit Rubber Feet – <b>Counter Top Only</b>		
24	Bottom Panel <b>Counter Top Only</b>		
25	Compressor 220-240V / 50Hz R600a Compressor 120V/60Hz R134a		
28	Solenoid Mounting Bracket <b>Counter Top Only</b>		
29	Bulkhead Union ¼" x ¼" John Guest P/N PI1208S		
30	Wire Condenser <b>Counter Top Only</b>		









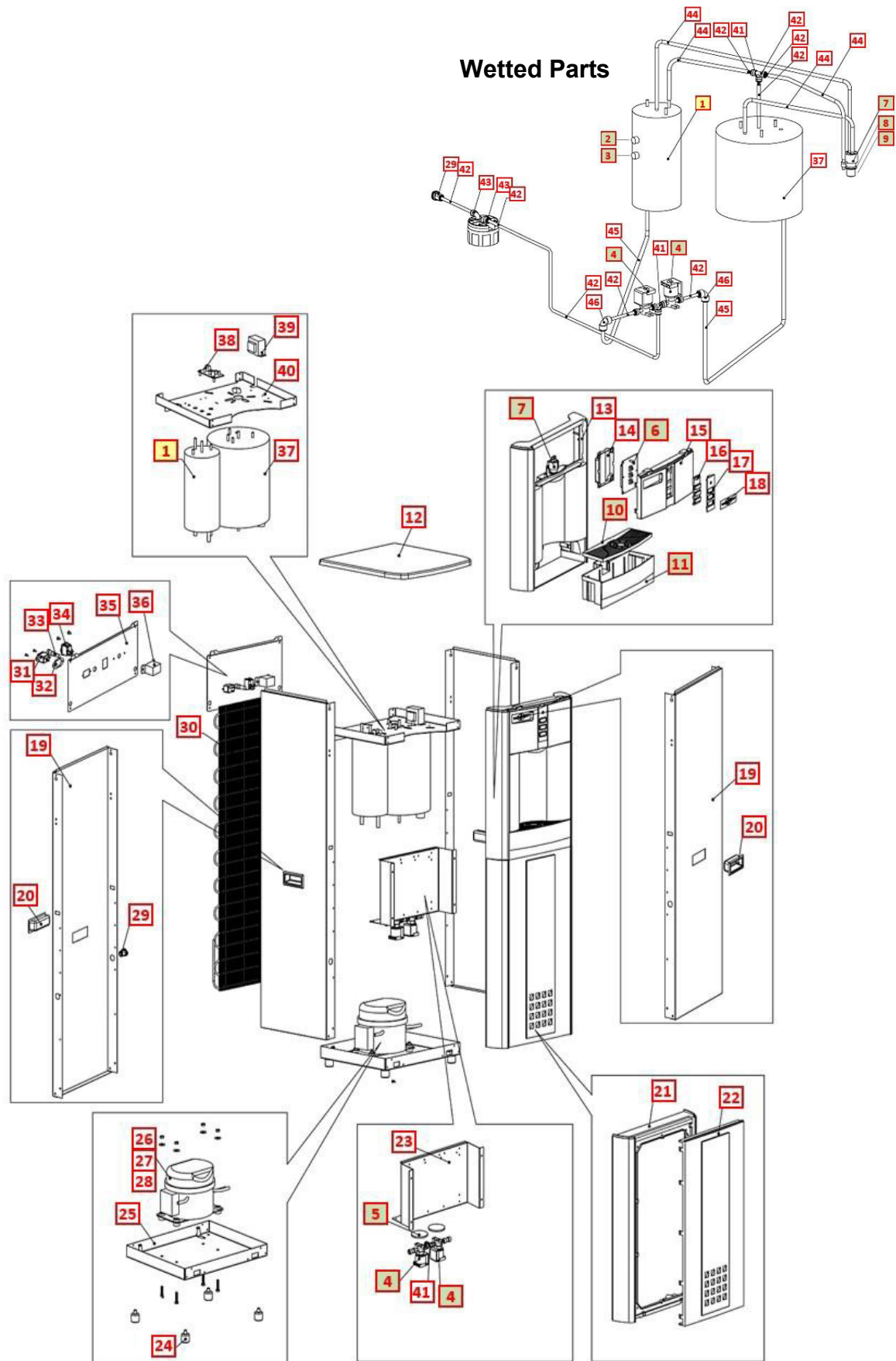

31	Cold Tank Thermostat		
32	Socket for Plug Connection		
32.1	Gasket for Power Socket		
33	Fuse Holder and Fuse 220V / 10A with One Wire Fuse Holder and Fuse 120V / 15A with One Wire		
34	Red Heater and Compressor Switch		
35	Back Panel – Silver <b>Countertop Only</b>		
36	Silicon Tube 5/16" for Hot Water		
37	JG LLDPE Tube - Blue 8mm John Guest P/N PE-0806-100M-B		
38	JG LLD PE Tube - Blue O.D.1/4" John Guest P/N PE-08-BI-1000F-B		
39	5/16" X 1/4" Reducing Elbow John Guest P/N PI211008S		
40	1/4" Union Elbow John Guest P/N P10308S		
41	1/4" Union Tee John Guest P/N P10208S		
25a	Plastic PCB Support		
Not Shown	Wire Harness Set		













Not Shown	Solenoid Valve Harness 1000mm		
Not shown	Wire Connector between Hot Tank and Thermostat		
Not Shown	Power Cord EU – 220V / 50Hz Power Cord UK – 220V / 50Hz Power Cord US – 120V / 60Hz		

# C100 FREE STANDING EXPLODED DIAGRAM AND PARTS LIST



No	Description	
1	Hot Tank 1.5 Litre 220-240V / 500W Factory Set Point 85°C (185°F)  Hot Tank 1.5 Litre 120v/500W Factory Set Point 85°C (185°F)	
Not Shown	GAC Filter - 10" Carbon Activated Inline Filter – <b>Optional</b>	
Not Shown	Carbon Block - 10" CBC 1 Micron Lead and Cyst Reduction Inline Filter – <b>Optional</b>	
1.1	Thermostat and Overload Metal Cover <i>Recommend stocking 2 each for every 10 units purchased</i>	
2	Overload with Manual Reset 97° C <i>Recommend stocking 2 each for every 10 units purchased</i>	
3	Hot Tank Thermostat 85°C <i>Recommend stocking 2 each for every 10 units purchased</i>	
4	Solenoid Valve with Terminal at Outlet Position <i>Recommend stocking 5 each for every 10 units purchased</i>	
5	Solenoid Cushion <i>Recommend stocking 5 each for every 10 units purchased</i>	
6	Main PCB <i>Recommend stocking 2 each for every 10 units purchased</i>	
7	Faucet Assembly <i>Recommend stocking 2 each for every 10 units purchased</i>	
8	Natural Faucet O-Ring – Silicon White <i>Recommend stocking 2 each for every 10 units purchased</i>	

9	Faucet Nipple – Blue with Screen <i>Recommend stocking 2 each for every 10 units purchased</i>		
10	Drip Tray Grill Charcoal <i>Recommend stocking 5 each for every 10 units purchased</i>		
	Drip Tray Grill – Blue <i>Recommend stocking 5 each for every 10 units purchased</i>		
11	Drip Tray Body – No Logo <i>Recommend stocking 5 each for every 10 units purchased</i>		
	Drip Tray Body – Blue No Logo <i>Recommend stocking 5 each for every 10 units purchased</i>		
12	Top Cover Flat - Charcoal Textured		
	Top Cover Flat – Blue		
13	Front Upper Drip Tray Insert Panel - - when purchasing, also request Hot Water Caution Label LP-7169 to adhere to front of this Panel.		
13.1	Hot Water Caution Label – Adhere to Front Upper Drip Tray Insert Panel.		
14	Front PCB Cover		
15	Front Upper Insert Panel - Charcoal		
	Front upper Insert Panel – Blue		



16	Silicon Button Key mat		
17	Button PCB Insert Panel - Silver		
18	<b>C100</b> Label – Front Upper Insert Panel		
19	Side Panel - <b>Free Standing Only</b>		
20	Side Panel Plastic Handle - <b>Free Standing Only</b>		
21	Front Lower Panel <b>Free Standing Only</b>		
22	Front Lower Insert Panel - Charcoal <b>Free Standing Only</b>		
	Front Lower Insert Panel - Blue <b>Free Standing Only</b>		
23	Filter Fixing Bracket - <b>Free Standing Only</b>		
24	Unit Control Rubber Feet - <b>Free Standing Only</b>		
25	Bottom Tray- <b>Free Standing Only</b>		

26	Compressor 220-240V / 50Hz R600a		
29	Bulkhead Union ¼" x ¼" John Guest P/N PI1208S		
30	Wire Condenser - <b>Free Standing Only</b>		
31	Socket for Plug Connection		
32	Gasket for Power Socket		
33	Fuse Holder and Fuse 220V / 10A with One Wire  Fuse Holder and Fuse 120V / 15A with One Wire		
34	Red Heater and Compressor Switch		
35	Back Panel <b>Free Standing Only</b>		
36	Cold Tank Thermostat		
36.1	Cold Adjustment Cover Label		
37	2 Litre Cold Tank <b>Free Standing Only</b>		
38.2	Plastic PCB Support		
39	Power Transformer 230V / 50Hz  Power Transformer 120V / 60Hz		

40	Upper Shelf - <b>Free Standing Only</b>		
41	¼" Union Tee John Guest P/N P10208S		
42	JG LLD PE Tube - Blue O.D.1/4" John Guest P/N PE-08-BI-1000F-B		
43	1/4" Union Elbow John Guest P/N P10308S		
44	Silicon Tube 5/16" for Hot Water		
45	JG LLDPE Tube - Blue 8mm (PE-0806-100M-B)		
46	5/16" X ¼" Reducing Elbow John Guest P/N PI211008S		
Not Shown	Wire Harness Set		
Not Shown	Solenoid Valve Harness 1000mm		
Not shown	Wire Connector between Hot Tank and Thermostat		
Not shown	2.8" Filter Clip for In-Line Filter 3" Filter Clip for In-Line Filter		
Not Shown	Power Cord EU – 220V / 50Hz Power Cord UK – 220V / 50Hz Power Cord US – 120V / 60Hz		

## C100 WATER FLOW DIAGRAM

Hot and Cold

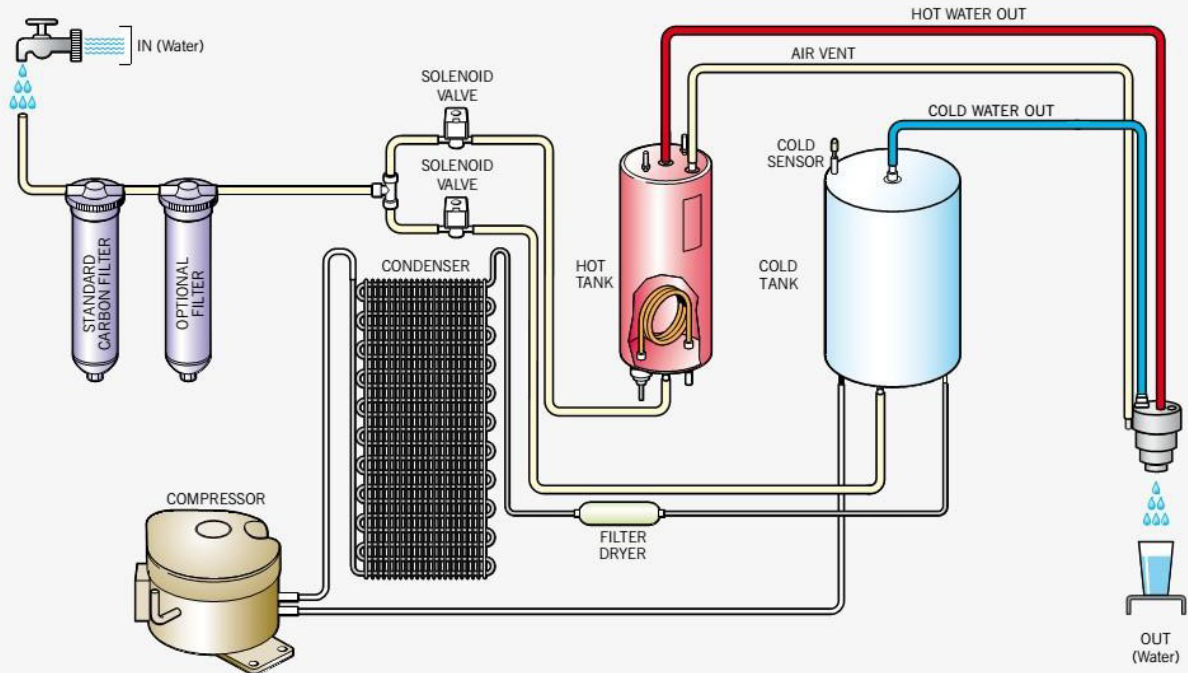



### Cold and Ambient

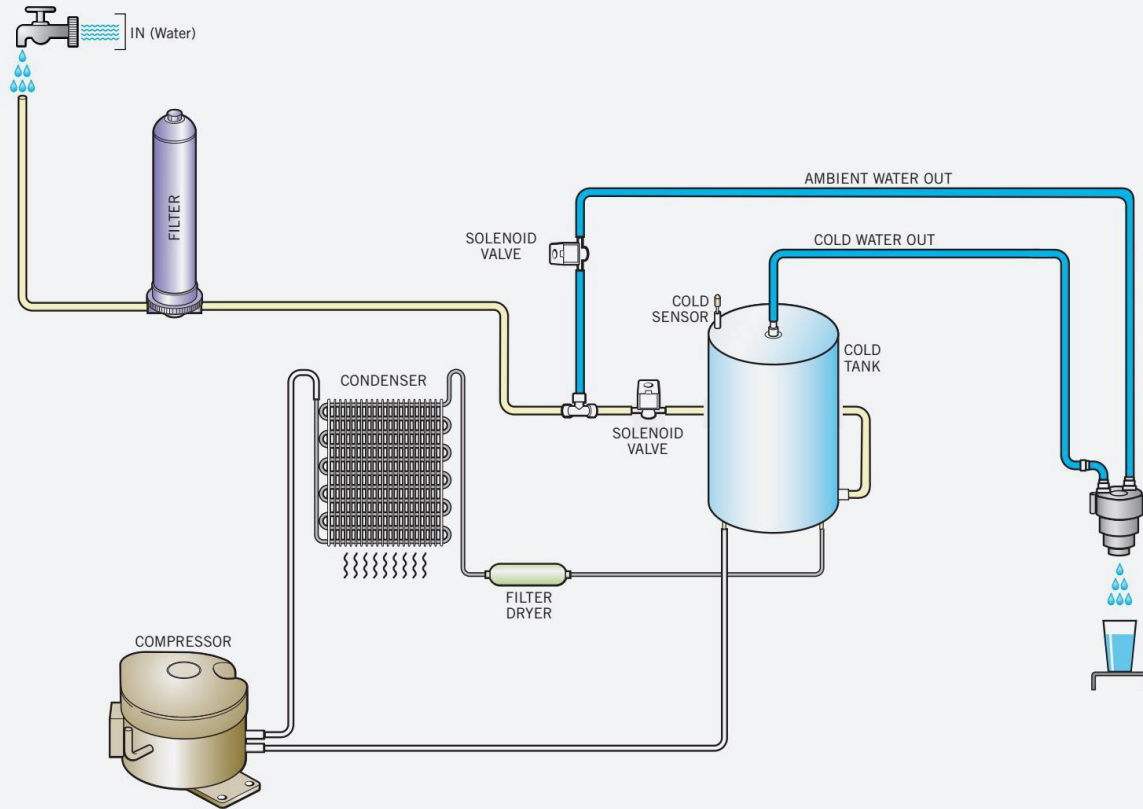

# C100 WATER ELECTRICAL SCHEMATIC DIAGRAM

**⚠ DANGER!** HIGH VOLTAGE ELECTRICAL HAZARD. PCB (Printed Circuit Board) contains High Voltage. Only trained and qualified technicians should attempt live testing.

220V

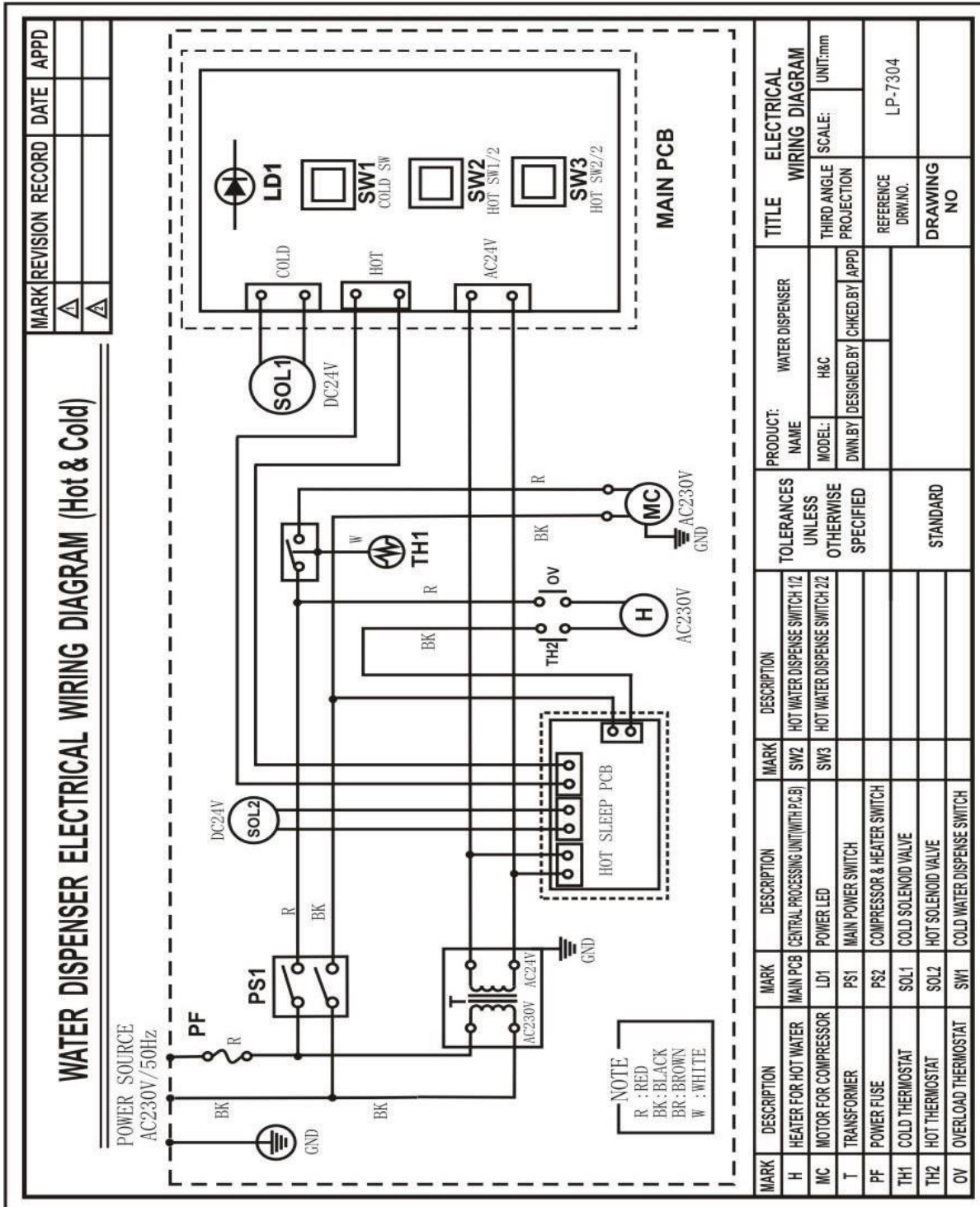

120V

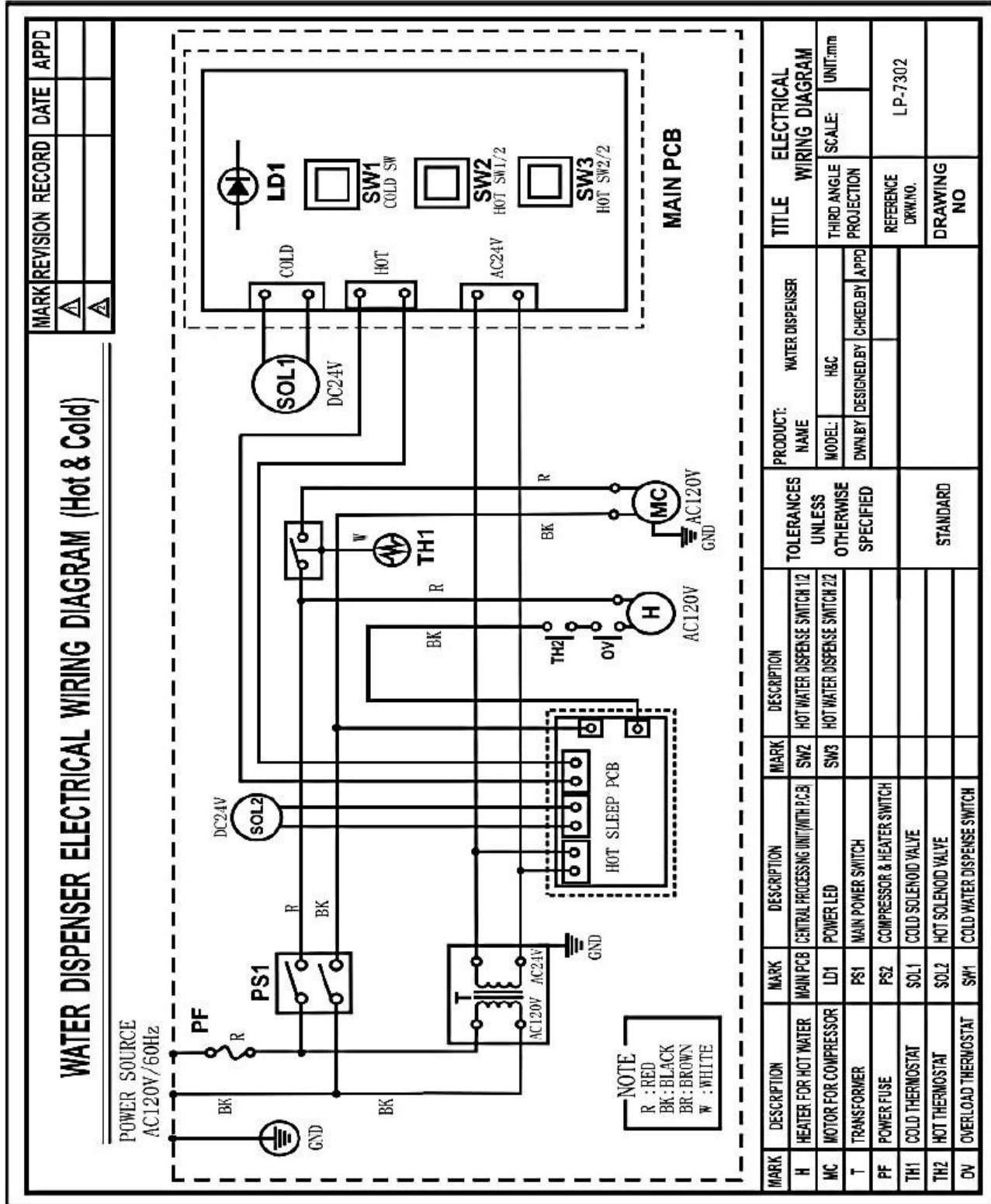

## PRE-DELIVERY PROCEDURES

 **DANGER!** *ELECTRICAL SHOCK HAZARD.*

*Only qualified personnel who have read and understand this entire manual should attempt to install, or service this **C100 Water Treatment System**, failure to do so could result in death or serious injury. DO NOT plug into an electrical supply until specifically instructed.*

 **WARNING!** *ALWAYS SANITISE BEFORE USE.*

*Sanitise before use to eliminate any potential microbiological contaminates.*

### Materials Needed:

- Personal Protective Equipment. Rubber or Nitrile Safety Gloves and Protective Eyewear
- Phillips Screwdriver.
- Temperature Gauge.
- Water Pitcher or Container to collect water from the faucet
- 3 Litre container or drain basin
- Aquadosa Sanitiser – Or equivalent (5.25% Sodium Hypochlorite)
- 1/4" O.D. Plastic Tubing, at least 1.5m in length, and assorted 1/4" quick connect fittings.
- Test Strips for measuring sanitiser levels
- TDS Meter (Optional)
- Empty filter housing

1. Unpack the **Culligan C100 Water Treatment System** and check exterior for damage.

### Flush Filters

 **CAUTION!** *FILTER FLUSH REQUIRED.*

*C100's Water Treatment Systems are not supplied with filters. Filters should be configured to optimize your system. Filters need to be configured and specified to do the job given the local water conditions, usage, maintenance schedule, and placement restrictions.*

*In order for our filters to perform as represented and to provide the best quality water possible, it is essential that filters be replaced periodically. The frequency of filter changes depends upon your water quality and your water usage. For example, if there is a lot of sediment and/or particles in your water, then you will have to change your filters more frequently than a location with little to no sediment. Be sure to replace your filters whenever you notice a decline in the performance, whether it is a drop in flow rate and/or pressure or an unusual taste in the water.*

2. Flush thoroughly with fresh water to drain.
3. Once flushed, install the filters. Following the flow direction on the filter.

**NOTE:** Filters should not be flushed prior to 24 hours before installation to limit Microbial Growth. Filters must be flushed upon installation.

## Sanitising

Sanitise using Aquadosa or a 5.25% Sodium Hypochlorite solution or other approved cleaner throughout the cold and sparkling water circuits. Follow all instructions on the sanitiser and flush with fresh water through the faucet until odour and taste is acceptable.

**⚠️ WARNING! USE PROPER PERSONAL PROTECTIVE EQUIPMENT**

*Always ensure proper ventilation and use proper personal protective equipment such as gloves and eye protection when using chemicals. Refer to Material Safety Data Sheet for specific requirements of each chemical product. Take all necessary precautions to prevent sanitiser from contacting eyes, clothing, and any other surfaces (it could damage carpets).*

4. Mix 60ml of Aquadosa sanitiser per directions or follow manufactures instructions. Always ensure sanitiser is compatible with stainless steel and acetyl plastic.
5. Pour sanitiser solution into an empty filter housing. You may add concentrated sanitiser directly into empty cold tank instead of premixing. Connect to the bulkhead fitting located on the back of the **C100 Water Treatment System**.
6. Connect 2.7-4 Bar regulated, potable water supply to the filter housing with the sanitising solution in. Turn on water supply and check for leaks.

**⚠️ DANGER! ELECTRICAL SHOCK HAZARD.**

*Do not plug in unit unless qualified. Only qualified personnel who have read and understand this entire manual should attempt to install or service this unit.*

7. Connect **C100 Water Treatment System** to power.

**⚠️ CAUTION! NEVER TURN ON HEATER BEFORE FILLING HOTTANK.**

*Red Heater and Compressor Power Switch must be in the O=OFF position while the hot tank is empty. Damage could occur within one minute and the overheat (high limit) will require manual reset if heater is turned on with an empty hot tank.*



## Fill the Cold Circuit with Sanitiser

8. Depress the main dispensing button on the front control panel until cold water/sanitising solution comes out the faucet. **NOTE:** Container and drain basin will be required to catch the water from the faucet.

**⚠️ WARNING!** Use Personal Protective Equipment. Gloves and Eye Protection Required. The first 2 or 3 litres of water will contain concentrated sanitiser. Use extreme care!

### Flushing the Sanitiser from the Machine

9. Place a pitcher, catch basin, or other container under the faucet of the **C100 Water Treatment System**.
10. Flush the Cold Tank. Run a minimum of 10 litres through the faucet by dispensing cold water to dilute and remove the sanitiser from the cold circuit. You can use test strips to evaluate the water. Ensure 0ppm are left within the cold tank.
11. Once the sanitiser odour/taste has been flushed out of the cold side of the machine the sanitisation process for the Cold Circuit is complete.

### Fill the Hot Tank

12. Press the Hot Water Select Button, followed by the main dispensing button to fill the hot tank. Water will dispense from the faucet once the hot tank is full. Flush until water is clear.

 **WARNING!** *HOT CIRCUIT IS NOT SANITISED.*

*Water in the hot circuit is not sanitary until the temperature exceeds 77°C (171°F) for at least 5 minutes.*

### Compressor Test

13. Switch Red Compressor / Heater to *I=ON* position. Always ensure tanks are full of water before turning on the heater or the overheat (high limit) will open and require manual reset. If the wire condenser at back of the **C100 Water Treatment System** is warm, the refrigeration system is working.



14. Once the machine reaches its target temperature, the compressor will shut off. Draw a glass of cold water and verify it has been chilled to proper temperature.

### Heater Test

15. Always ensure tanks are full of water before turning on the heater or the overheat (high limit) will open and require manual reset. It will take the heater approximately 10 minutes to heat the water from ambient 24°C (75°F) to the factory set point of 85°C (185°F). Dispense a cup of hot water to ensure the temperature/odour/taste is acceptable.

 **WARNING!** *HOT WATER. Unit produces Hot Water up to 87°C (188°F). Water above 52°C (125°F) can cause severe burns or scalding. Hot water should be dispensed carefully into insulated container to avoid injury.*



## C100 MINI DRAINING INSTRUCTIONS

### Draining Notes

Drain the **C100 Water Treatment System** for transportation.

 **WARNING!** *STORE UNIT EMPTY. ALWAYS SANITIZE BEFORE REUSE.*

*The unit must be completely drained and sealed before storing to avoid stagnation and reduce microbial growth).*

Prior to draining the Hot Tank, turn off the Red Heater and Compressor Switch – *O=OFF*, and dispense 2 Litres (½ Gallon) of hot water from the **C100 Water Treatment System**. As hot water is dispensed from the Faucet of the unit, colder water will be introduced into the Hot Tank. Since the Red Heater and Compressor Switch is turned off, the Heater will not energize and heat the incoming tap water.



Following this precaution prevents exposing personnel and equipment (drains, catch basin, etc.) from scalding hot water.

### Disable Cold and Hot Tanks

1. Turn off the Red Heater and Compressor Switch to disable the Heater and Compressor. *Red Compressor/Heater Switch must be in the O=OFF position*
2. Dispense 2 litres of water through the Hot Tank to cool the water temperature in the Hot Tank and avoid burns.



 **WARNING!** *HOT WATER. Unit produces Hot Water up to 87 °C (189°F). Water above 52°C (125°F) can cause severe burns or scalding. Hot water should be dispensed carefully into insulated container to avoid injury.*

### Turn off Water Supply and Bleed Water Pressure

3. Isolate **C100 Water Treatment System** from feed water by turning off the supply.
4. Dispense cold still water to relieve any pressure built up in the system.

### Drain the Cold Water Tank and Circuit

5. Remove Top Cover.

6. Remove Front Panel. Remove 2 Phillip screws securing Front Panel.

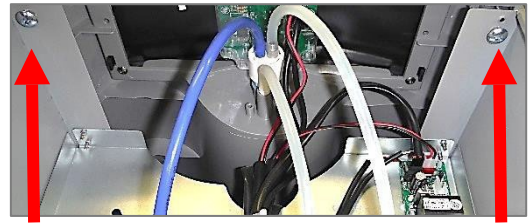

7. Unseat Faucet Assembly from Front Panel.



8. Unclip the White, Red and Black wire connectors from PCB to allow Front Cover to be removed.

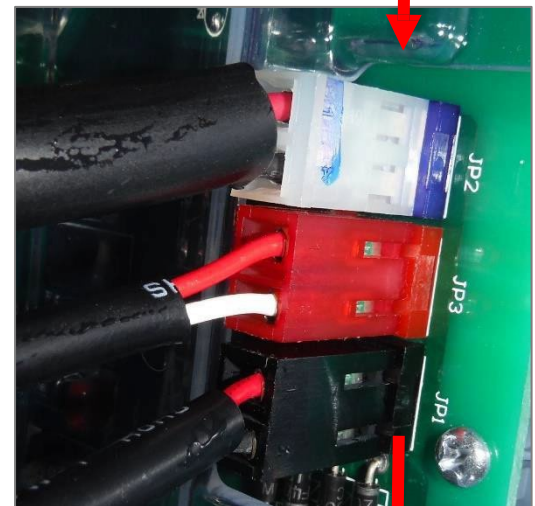

9. Remove Front Panel

10. Disconnect tubing to allow water to drain from the **C100 Water Treatment System**.

Catch water in a pitcher, catch basin or another container.

11. Dry inside of the **C100 Water Treatment System**.

12. Replace Front Panel.





## C100 FREE STANDING DRAINING INSTRUCTIONS

### Draining Notes

Drain the **C100 Water Treatment System** for transportation.

**⚠️ WARNING! STORE UNIT EMPTY. ALWAYS SANITIZE BEFORE REUSE.**

*The unit must be completely drained and sealed before storing to avoid stagnation and reduce microbial growth).*

Prior to draining the Hot Tank, turn off the Red Heater and Compressor Switch (*O = OFF*) and dispense 2 litres of hot water from the **C100 Water Treatment System**. As hot water is dispensed from the faucet of the unit, colder water will be introduced into the Hot Tank. Since the Red Heater and Compressor switch is turned off, the Heater will not energize and heat the incoming tap water. Following this precaution prevents exposing personnel and equipment (drains, catch basin, etc.) to scalding hot water.



*Red Compressor/Heater Switch must be in the O=OFF position.*

### Disable Cold and Hot Tanks

1. Ensure the Red Heater and Compressor Switch is off (*O = OFF*) to disable the Heater and Compressor.
2. Dispense 2 litres of water through the Hot Tank to cool the water temperature in the Hot Tank and avoid burns.



**⚠️ WARNING! HOT WATER. Unit produces Hot Water up to 87°C (189°F). Water above 52°C (125°F) can cause severe burns or scalding. Hot water should be dispensed carefully into insulated container to avoid injury.**

4. Dispense cold still water to relieve any pressure built up in the system.

### Drain the Cold Water Tank and Circuit

5. Remove the Lower Front Panel to access tank feed lines.

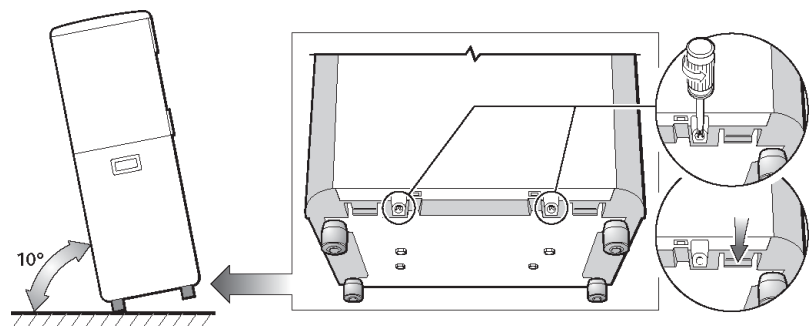

6. Remove the Hot and Cold water supply lines from the inlet line Solenoids.

7. Disconnect tank line outlet lines from Hot and Cold Solenoids to drain into basin or bucket.

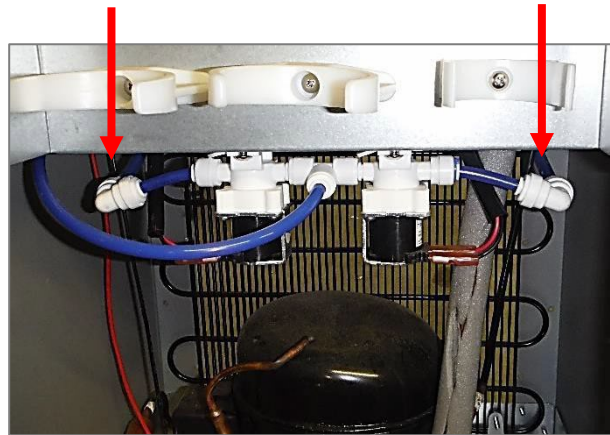

8. Turn outlet fittings outward to avoid water spilling onto the Compressor.

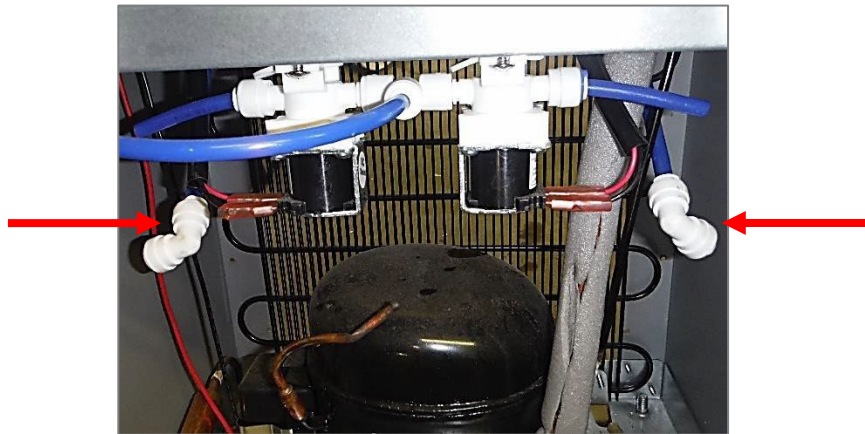

9. Reconnect Tubing into Outlet Elbows once drained.







10. Dry inside of Bottom Tray as necessary.

11. Replace Lower Front Panel

## INSTALLATION PROCEDURES

### Safety and Installation Guidelines

Ensure all Local Laws and Codes including health and safety guidelines are met when installing **Culligan** Equipment. Only qualified service technicians should attempt installation and service of **Culligan** Equipment.

-  **WARNING! ELECTRICAL SHOCK HAZARD.** Always unplug (isolate from power supply) to prevent electrical shock except where electrical tests are specified.
-  **WARNING! IMPROPER SUPPLY OR CONNECTION CAN RESULT IS RISK OF SHOCK.** Connect to a 13 amp 220/240V 50Hz properly grounded outlet (GFI is recommended). Ensure polarity is correct and always use a 3-prong outlet. Consult a qualified electrician if you have any questions.
-  **WARNING! ONLY USE A Culligan SUPPLIED POWER CORD.** Locate system within 1 meter of power supply. Never use an extension cord or adapter. Do not use a damaged power cord or plug. Keep power cord out of heavy traffic areas and away from heat sources. Do not, under any circumstances, remove ground prong or alter the power cord. Never pull the power plug from the outlet with a wet hand or allow the plug to get wet. Failure to use the supplied power cord will void UL Certification and Warranty.
-  **CAUTION! INDOOR USE ONLY.** Never expose to direct sunlight, heat sources, or ambient air temperature above 37°C (100°F) or below 2°C (35°F). Install indoors and keep unit away from excessive humidity. Never expose to freezing temperatures. Ensure there is adequate clearance around the unit to allow refrigeration system condenser to dissipate heat. Warmer environments require more clearance around the unit. Minimum clearance around all surfaces of the machine is 50mm. Installs where the ambient temperature exceeds 27°C (80°F), require a minimum of 100mm clearance for proper heat dissipation and efficient operation.
-  **CAUTION! USE A WATER PRESSURE REGULATOR.** **Culligan** will not be responsible for injury or damage caused by excessive water pressure. Operating pressure must be 2.7 to 4bar. Be aware of any potential pressure surges caused by building/municipal pumping stations.
-  **CAUTION! USE UV STABILIZED SUPPLY LINES.** Feed the unit with a potable ambient or cold water supply only. Feed water over 37°C (100°F) can damage the treatment components. Water block devices and external leak detectors are strongly recommended. Locate the unit as close to the water supply and the electrical connections as possible.
-  **WARNING! STORE AND TRANSPORT UNIT EMPTY. ALWAYS SANITIZE BEFORE USE.** The unit must be completely drained and sealed before storing to avoid stagnation and reduce microbiological contamination (potential bacterial growth). Sanitize before use to eliminate any potential microbiological contaminates

Pre-delivery and sanitization procedures as prescribed in this manual must be performed before installing the **C100 Water Treatment Systems**.

Always install indoors and place the **Culligan C100 Water Treatment System** on a firm, flat and stable surface.

1. Attach the water supply line to the 1/4" feed water inlet bulkhead fitting on the back of the unit. **Culligan** requires the use of a water pressure regulator. Water feed pressure must be between 2.7-4bar. Turn on the water supply and check for leaks.

2. Check to ensure that the Red Compressor & Heater switch is the *O=OFF* position.



**NOTE:** Switch has internal LED that illuminates when placed in *I=ON* position.

3. Connect the power cord to the back of the **Culligan C100 Water Treatment System** and to a 220/240 Volt supply.
4. Fill the Cold Tank. Hold a container under the dispensing faucet, press and hold the main dispensing button until a continuous flow of water is obtained. Once a continuous flow is obtained, release the dispensing button. Cold Tank is now full.
5. Fill the Hot Tank. Hold a container under the dispensing faucet. Press the Hot Select Button followed by the main dispensing button until a continuous flow of water is obtained. Once a continuous flow is obtained, release the main dispensing button. Hot tank is now full.

**⚠ CAUTION! NEVER TURN ON HEATER BEFORE FILLING HOTTANK.**

*Red Compressor/Heater Switch must be in the O=OFF position while the hot tank is empty. Damage could occur within one minute and the overheat (high limit) will require manual reset if heater is turned on with an empty hot tank.*



6. Move the **Culligan C100 Water Treatment System** into its final operating position. Be sure that a minimum of 50mm clearance is maintained around both the sides and the back of the unit. This is important to allow proper airflow and heat exchange of refrigeration system.
7. Level unit using the adjustable feet to level if necessary. Never install on incline.
8. Turn the Red Compressor & Heater Power Switch to *I=ON* position.
9. When the unit has reached its Hot Temp Set Point, the heater will cycle off.  
When the unit has reached its Cold Temp Set Point Temperature, the compressor will cycle off.
10. Once the unit is at the target temperature(s), sample the water to ensure water meets expectations and additional rinsing or adjustment is not required.
11. Check the **C100 Water Treatment System** for any leaks. External Leak Protection is always recommended.



## AUSTRALIAN INSTALLATION GUIDE

*Installation in accordance with AS/NZS 3500.1 and AS/NZS 3500.2.*

*Culligan units must be installed according to the local guidelines. Culligan units should only be connected to a potable drinking water supply. Culligan units should not be connected to water supplies of unknown bacterial quality or those not already fit for human consumption.*

*Culligan International strongly recommends the use of an anti-flood device.*

### *Installation Instructions and parts required*

1. *K001 Install kit as below, (1 x 63058/103988 – brass tee, 1 x 54011/104115 ball valve, 1 x 52028/104177 dual check valve)*



2. *Serialised Unit*
3. *Diamond Flow Filter and Head*

### *Options to above PLV*

*RMC PVDC50 dual check valve – 350 kpa PLV code 52010 / 100665*

### *Accessories*

1. *JG ¼ sf x 3/8 stem elbow x 2 (for filter head) 60157 / 100963*
2. *JG ¼ sf x ¾ npt tap adaptor 60175 / 104065*
3. *Water block 50000 / 101084*
4. *JG ¼ sf x ¼ sf isolating valve 60127 / 100932*
5. *JG ¼ tube (black only) x 5 meters 60800 / 104105 roll*
6. *JG ¼ locking clips x 5 60124 / 104162*

*Any installation that requires us to run water ≥ 5M to our unit, must be using AUSPEX or a Watermark equivalent product for all tubing runs. For our compliance the product we use to run the water from the source to our unit must be Watermarked.*

*After hours sales/service – 1300 88 14 14*

## POWER TROUBLESHOOTING INDEX

1. Red Heater and Compressor Power Switch won't light and the Red LED on the Front won't light
2. Red Power Switch is lit but the red LED on the Front is not lit
3. Compressor Runs but does Not Chill
4. Compressor is Not Running

### **1. Red Heater and Compressor Power Switch won't light and the Red LED on the Front won't light**

Possible Reason	Solution
Circuit Breaker	Check the Circuit Breaker
Fuse is Blown	Replace Fuse
Defective / Loose Power Cord	Check that power cord is properly plugged in. If it is properly plugged in, use a different power cord to verify.
Failed Power Line Noise Filter, Electromagnetic Interference filter (EMI)	Replace EMI
Defective Red Heater / Compressor Switch	Replace Red Heater / Compressor Switch

## 2. Red Power Switch is lit but the Red LED on the Front is not lit



Possible Reason	Solution
Bad Transformer	Replace Transformer
Black Power Connector to the PCB is not properly connected	Properly connect.
Bad Front PCB	Replace Front PCB
Bad Energy Saver PCB	Replace Energy Saver PCB
Defective Red Heater / Compressor Switch	Replace Red Heater / Compressor Switch

## 3. Compressor Runs But Does Not Chill

Possible Reason	Solution
Condenser is dirty	Clean the condensing coil of any obstructions or dust.
Reduction of airflow into unit.	Make sure unit is not under minimum ventilation requirements (50mm to 100mm).
Compressor is running very hot.	Low or lost refrigerant. Refrigerant recharge required.



#### 4. Compressor is Not Running

Possible Reason	Solution
<p>Red Heater and Compressor Switch button on unit is in the off position</p>	<p>Turn Red Heater and Compressor Switch on. <i>I = ON</i></p> 
<p>Compressor Starting Circuit</p>	<p>Turn Red Heater and Compressor Switch off. <i>O = OFF.</i></p> <p>Remove the Compressor cap on side of the Compressor;</p> <p>Disconnect the black and red terminal connectors;</p> <p>Inspect the starter and overload relay for any defects.</p> <p>Replace components(s) as needed.</p> <p>Turn Red Heater and Compressor Switch on <i>I = ON</i> and retest Compressor operation.</p>  



## DISPENSING TROUBLESHOOTING INDEX

1. Irregular / Intermittent Dispensing from One Side
2. Dispensing won't stop when not holding the Dispensing Button
3. Steady Drip out of Faucet
4. Hot Water or Steam coming out of both the Faucet and the Vent Hole
5. Hot Water coming out of Faucet Vent Hole
6. Restricted Flow of Hot Water
7. Hot Water Drip out of Faucet
8. Dispenses Hot and Cold Water at the same time
9. No cold water available
10. Water does not dispense from unit
11. Cold Water dispenses from Faucet and Vent Outlet Simultaneously
12. Small amount of water periodically dispenses from faucet automatically
13. Dispense Buttons Stick
14. Run-On - Water continues to dispense out of faucet after releasing the dispense button

## 1. Irregular / Intermittent Dispensing from one side

Possible Reason	Solution
<p>Too much water pressure. Recommend 2.7 to 4 bar for the <b>C100 Water Treatment System</b> to operate properly.</p>	<p>Check water pressure at the inlet bulkhead with a water pressure gauge.</p> <p>Additional method of verification is to turn off water to unit and press the dispense button. Does the Solenoid open without water pressure to the unit? Listen for Solenoid to activate, not to mistaken for the button “click”.</p> <p>Adjust water pressure to 2.7-4 bar . <i>The correct input water pressure is critical to the performance of the unit to allow Solenoids to open.</i></p>
<p>Loose or bad connection on the Front Dispensing PCGB or Solenoid Connector</p>	<p>Check that they are connected properly and tightened.</p>
<p>Solenoid</p>	<p>If both the Water Pressure and PCB have been ruled out, then it is the Solenoid.</p> <p>Replace Solenoid.</p>
<p>Dispensing button is broken on PCB</p>	<p>Check PCB for loose or damaged button. Replace PCB as necessary.</p>

## 2. Dispensing Won't Stop When Not Holding the Dispensing Button

Possible Reason	Solution
Too much water pressure. Recommend 2.7 to 4 bar for the <b>C100 Water Treatment System</b> to operate properly.	<p>Check water pressure at the inlet bulkhead with a water pressure gauge.</p> <p>Additional method of verification is to turn off water to unit and press the dispense button. Does the Solenoid open without water pressure to the unit? Listen for Solenoid to activate, not to mistaken for the button "click".</p> <p>Adjust water pressure to 2.7-4 bar . <i>The correct input water pressure is critical to the performance of the unit to allow Solenoids to open.</i></p>
Stem of the switch is broken on the PCB - Printed Circuit Board.	<p>Remove Display PC and inspect switches.</p> <p>Replace Display PCB if switches appear broken.</p>
Debris in the Solenoid	Inspect Solenoid for debris and clean out as needed.
Dispensing Button Stuck	Dirt or Foreign material is filling the gap around the push-buttons. Inspect the push buttons and clean surrounding area. Inspect faucet assembly inside the unit and clean as necessary.

## 3. Steady Drip Out of Faucet

Possible Reason	Solution
Debris in Solenoid	Inspect Solenoid for debris and clean out as needed.

#### 4. Hot Water or Steam Coming out of both the Faucet and Vent Hole

Possible Reason	Solution
Improper Tubing attachment from the Hot Tank to faucet or vice versa.	Check that the Tubing is connected from Tank Outlets to correct Faucet attachments. Connect Tubing to Outlets as needed.

#### 5. Hot Water Coming out of Faucet Vent Hole

Possible Reason	Solution
Too much water pressure. Recommend 2.7 to 4 bar for the <b>C100 Water Treatment System</b> to operate properly.	<p>Check water pressure at the inlet bulkhead with a water pressure gauge.</p> <p>Additional method of verification is to turn off water to unit and press the dispense button. Does the Solenoid open without water pressure to the unit? Listen for Solenoid to activate, not to mistaken for the button “click”.</p> <p>Adjust water pressure to 2.7-4 bar . <i>The correct input water pressure is critical to the performance of the unit to allow Solenoids to open.</i></p>
Improper tubing attachment from the tank to faucet or vice versa.	Verify tubing is connected properly from tank outlets to correct faucet attachments.
Hot Tank outlet hole is scaled over.	Inspect and Descale Tank as needed.
Expansion chamber is not sealed properly.	Replace the Hot Tank.

## 6. Restricted Flow of Hot Water

Possible Reason	Solution
Partially closed Water Supply Valve to the unit.	Open Water Supply Valve.
Hot Tank outlet hole is scaled over.	Descale Tank.
Tubing is creased or has a “kink” in it.	Inspect and replace tubing as necessary.
Faucet nipple screen mesh has obstruction(s)	Unscrew faucet nipple from faucet and remove any obstruction(s) from screen mesh.
Exhausted Filter	Replace the Filter
Solenoid connection to the Display PCB	Turn power off; unplug the unit and visually inspect Solenoid connections into the Display PCB. Verify the soldering points on connections are secure into the board. Remove the PCB to inspect the front of the board.
Solenoid Valve is Malfunctioning	Inspect valve components for proper function. Replace as necessary.

## 7. Hot Water Drip out of Faucet

Possible Reason	Solution
<p>Small Outlet Vent Hole susceptible to scale build up.</p>	<p>Descal Tank.</p>
	<p>All <b>Culligan</b> Hot Tanks have a built in Vent or Expansion Chamber in the top of the tank except for C1000GF units.</p> <p>The Vent Chamber allows for expansion of the water when it is heated.</p> <p>The chambers are separated by a welded-in tank baffle.</p> <p>Water always flows into the bottom of the tank and out the top to the faucet.</p> <p>The Hot Tank outlet tube has a restrictor in its base. This ensures the reservoir is always full by allowing more water in than out.</p> <p>There is a small hole in the side of the tank outlet tube that allows air and water to pass into the vent chamber as it is heated.</p> <p>Water in the vent chamber is suctioned back through the outlet tube vent hole when water is dispensed.</p> <p>Expansion of water as it is heated in the reservoir will push the water out the faucet when the outlet tube vent hole becomes plugged with debris or scale.</p> <p>The small Outlet Vent Hole is susceptible to scale build up and is a key indicator that descaling is required.</p> <p>It is critical to descale the Hot Tank through the vent line and outlet line on a regular basis to prevent this problem.</p> <p>Descaling through the inlet and/or outlet lines only will not clean the vent chamber and outlet vent hole properly.</p>

## 8. Dispenses Hot and Cold Water at the Same Time

Possible Reason	Solution
<p>Too much water pressure. Recommend 2.7 to 4 bar for the <b>C100 Water Treatment System</b> to operate properly.</p>	<p>Check water pressure at the inlet bulkhead with a water pressure gauge.</p> <p>Additional method of verification is to turn off water to unit and press the dispense button. Does the Solenoid open without water pressure to the unit? Listen for Solenoid to activate, not to mistaken for the button “click”.</p> <p>Adjust water pressure to 2.7-4 bar . <i>The correct input water pressure is critical to the performance of the unit to allow Solenoids to open.</i></p>
<p>Hot or Cold Solenoid is stuck open.</p>	<p>Remove Top Cover.</p> <p>Check Hot Solenoid: Dispense cold water and visually inspect tubing for water flow from both tanks.</p> <p>Check Cold Solenoid: Disconnect elbow from outlet of cold Solenoid. Select hot water and dispense (quickly releasing dispensing button to avoid much water coming out of cold Solenoid.</p> <p>Replace Solenoid as necessary.</p>

## 9. No Cold Water Available

Possible Reason	Solution
<p>Too much water pressure. Recommend 2.7 to 4 bar for the <b>C100 Water Treatment System</b> to operate properly.</p>	<p>Check water pressure at the inlet bulkhead with a water pressure gauge.</p> <p>Additional method of verification is to turn off water to unit and press the dispense button. Does the Solenoid open without water pressure to the unit? Listen for Solenoid to activate, not to mistaken for the button “click”.</p> <p>Adjust water pressure to 2.7-4 bar . <i>The correct input water pressure is critical to the performance of the unit to allow Solenoids to open.</i></p>
<p>Closed Water Supply Valve</p>	<p>Open the Water Supply Valve</p>
<p>Cold Water Solenoid Valve malfunction</p>	<p>Inspect the valve components for proper functionality.</p>
<p>Red Heater and Compressor Switch on unit is off.</p>	<p>Turn Red Heater and Compressor Switch on. I = ON</p> 
<p>Loose connection(s) on the Display PCB</p>	<p>Turn power off; unplug the unit and visually inspect Solenoid connections into the Display PCB. Verify the soldering points on connections are secure into the board.</p> <p>Remove the PCB to inspect the front of the board.</p>
<p>Exhausted Filter</p>	<p>Replace filters as needed.</p>



## 10. Water does not dispense from Unit

Possible Reason	Solution
<p>Too much water pressure. Recommend 2.7 to 4 bar for the <b>C100 Water Treatment System</b> to operate properly.</p>	<p>Check water pressure at the inlet bulkhead with a water pressure gauge.</p> <p>Additional method of verification is to turn off water to unit and press the dispense button. Does the Solenoid open without water pressure to the unit? Listen for Solenoid to activate, not to mistaken for the button “click”.</p> <p>Adjust water pressure to 2.7-4 bar . <i>The correct input water pressure is critical to the performance of the unit to allow Solenoids to open.</i></p>
<p>Closed Water Supply Valve</p>	<p>Open the Water Supply Valve.</p>
<p>The unit is not properly plugged into electrical outlet</p>	<p>Check electrical outlet connection, or for blown circuit breaker.</p>
<p>Red Heater and Compressor Switch on unit is in the off position</p>	<p>Turn Red Heater and Compressor switch on. <i>I = ON</i></p> 
<p>Fuse Blown</p>	<p>Replace the Fuse as needed.</p>
<p>Hot and Cold Solenoid connections into the Display PCB are loose.</p>	<p>Turn power off; unplug the unit and visually inspect Solenoid connections into the Display PCB. Verify the soldering points on connections are secure into the board.</p> <p>Remove the PCB to inspect the front of the board.</p>
<p>Exhausted Filter</p>	<p>Replace filters as needed.</p>

### **11. Cold Water Dispenses from Faucet and Vent Outlet Simultaneously**

Possible Reason	Solution
Improper tubing attachment from the tank to faucet or vice versa	Verify tubing is connected properly from tank outlets to correct faucet attachments.
Scale has formed inside Cold Tank outlet tube.	Remove Cold Water Outlet Tube from Cold Tank to Faucet.
Expansion chamber in Cold Tank is not sealed properly.	Replace Cold Tank.

### **12. Small Amount of Water Periodically Dispenses from Faucet Automatically**

Possible Reason	Solution
Too much water pressure. Recommend 2.7 to 4 bar for the <b><i>C100 Water Treatment System</i></b> to operate properly.	<p>Check water pressure at the inlet bulkhead with a water pressure gauge.</p> <p>Additional method of verification is to turn off water to unit and press the dispense button. Does the Solenoid open without water pressure to the unit? Listen for Solenoid to activate, not to mistaken for the button “click”.</p> <p>Adjust water pressure to 2.7-4 bar . <i>The correct input water pressure is critical to the performance of the unit to allow Solenoids to open.</i></p>
Cold or Hot Water Solenoid valve malfunction	Inspect valve components for proper function. Replace as necessary.
Obstruction in Solenoid housing is preventing proper sealing of component.	<p>Pre-determine whether water being dispensed is hot / cold. Isolate the water supply; push the DISPENSE button to release the line pressure, and remove the coil affixed to the Solenoid stem.</p> <p>Remove the stem from the Solenoid housing and allow water from the tank to flush out the contaminant(s).</p>

### 13. Dispense Buttons Stick

Possible Reason	Solution
Dirt or Foreign material is filling the gap around the push-buttons.	<p>Inspect the push buttons and clean surrounding area.</p> <p>Inspect faucet assembly inside the unit and clean as necessary.</p>

### 14. Run On – Water continues to dispense out of faucet after releasing the dispense button

Reason																														
<p>“Run On” or “Carry On” is present in all Culligan pressure fed units without outlet Solenoids.</p> <p>“Run On” is defined is the amount of water that continues to dispense out of the faucet after releasing the dispense button.</p> <p>Run On exists because the tanks pressurize as water is being dispensed. Every Culligan tank has an outlet restrictor to ensure the tanks remain full of water and water is controlled as it is released to the faucet. The inlet Solenoid controls flow into the tanks. The tanks will “depressurize” once the dispense button is released the inlet Solenoid closes. A small amount of water will “Run On” through the faucet as the tank depressurizes to atmospheric conditions.</p> <p>Typical “Run On” is 2-3 seconds.</p> <p><b>“Run On” can be reduced by installing a pressure limiting device.</b></p> <p>The amount of inlet or supply pressure directly impacts the amount of “Run On” as quantified below.</p> <table border="1"> <thead> <tr> <th colspan="5">Culligan Lab Testing of Run On</th> </tr> <tr> <th>Pressure</th> <th>Pressure</th> <th>Time</th> <th>Flow Rate</th> <th>Run On</th> </tr> <tr> <th>Static Bar</th> <th>Dynamic Bar</th> <th>4 Litres</th> <th>l/min</th> <th>Seconds</th> </tr> </thead> <tbody> <tr> <td>4.6</td> <td>2.7</td> <td>61</td> <td>2.9508197</td> <td>3</td> </tr> <tr> <td>3.4</td> <td>2</td> <td>72</td> <td>2.5</td> <td>2.5</td> </tr> <tr> <td>2.2</td> <td>1.3</td> <td>92</td> <td>1.956217</td> <td>2</td> </tr> </tbody> </table> <p>Pressure measured at inlet line to unit. Static with unit closed. Dynamic with unit dispensing cold water.</p> <p>No filters were installed in unit.</p>	Culligan Lab Testing of Run On					Pressure	Pressure	Time	Flow Rate	Run On	Static Bar	Dynamic Bar	4 Litres	l/min	Seconds	4.6	2.7	61	2.9508197	3	3.4	2	72	2.5	2.5	2.2	1.3	92	1.956217	2
Culligan Lab Testing of Run On																														
Pressure	Pressure	Time	Flow Rate	Run On																										
Static Bar	Dynamic Bar	4 Litres	l/min	Seconds																										
4.6	2.7	61	2.9508197	3																										
3.4	2	72	2.5	2.5																										
2.2	1.3	92	1.956217	2																										

## COLD WATER TROUBLESHOOTING INDEX

### Cold Water is not Cold (5° +/- 3°C)

Possible Reason	Solution
No power or refrigeration elements	<p>Check that the Red Heater and Compressor switch is on.</p> <p style="text-align: right;"></p> <p>TURN RED HEATER AND COMPRESSOR SWITCH ON / - ON</p>
<p>Tank has run out of cold water.</p> <p><i>Cold Tank capacity:</i></p> <p><i>Tower: 4 litres (1 Gallon)</i></p> <p><i>Counter Top: 2 Liters (1/2 Gallon)</i></p>	<p>Wait for Cold Tank to chill water to temperature prior to dispensing more cold water.</p> <p>A greater capacity of <b>Culligan</b> Water Systems is available.</p>
Cold Water Thermostat	Check continuity of thermostat with multimeter. Replace thermostat as required.
Refrigerant has run out	Run Compressor for at least ten minutes. If condenser is not warm then refill the refrigerant.
Compressor problem	If Compressor is not running, repair or replacement is needed.

## HOT WATER TROUBLESHOOTING INDEX

### Hot Water is not Hot 85°C ± 5°C

The Hot Temperature set point is 85°C (185°F) and is controlled by a thermostat on the side of the Hot Tank.

There is a resettable overload or high limit safety above the thermostat on the side of the Hot Tank that will trip to prevent damage to the unit if the tank is dry heated (turned on without water in it).

The **C100 Water Treatment System** does NOT have Extra Hot capability and the maximum hot temperature is 87°C (189°F).

It typically takes 10 minutes for the 500W to heat the 1.5 Litre of room temperature (ambient) water to the 85°C (185°F) set point.

Possible Reason	Solution
No power to Heater elements	Check that the Red Heater and Compressor switch is on.  Turn Red Heater and Compressor Switch on. <i>I = ON</i> 
Hot Tank Overheat Tripped  <i>Overheat is a safety feature to ensure the tank does not overheat.</i>	Overheat will “click” when pushed. The overload is automatically reset when pressed.
Thermostat or over heat “open” on Hot Tank	Turn Power off. Check OHM’s resistance across terminals on each Thermostat and Overload separately.  Good components will indicate a closed circuit or zero OHM’s on the meter.  Replace components as necessary.
Loose or improperly connected wire(s) to the heating element / Hot Tank.	Visually inspect wire leads going to the Hot Tank; confirm proper connections to the heating elements.  Hot Tank life is 3-5 years depending on usage, depending on usage.
Heating Coil Not Working	Turn Power off; Drain Hot Tank; Use multi-meter to check Heater element for approximately 26 OHM’s resistance.  Hot Tank must be empty if you are checking for continuity.  Replace Hot Tank as necessary.